

WWTAC09

IWA Speciality Conference:
2nd International Symposium on

Water and Wastewater Technologies in Ancient Civilizations

May 28th | 29th | 30th Bari | Italy **2009**

Organized by:



International
Water Association

In collaboration with:



FederUtility

With the contribution of:

AQP SpA of Bari

INDEX 

The Roman Aqueduct and the Helvius' Fountain in Sant'Egidio del Monte Albino, in Southern Italy: A Historical and Morphological Approach

*G. De Feo**, *S. De Gisi**, *C. Malvano**, *A. Tortora***, *S. Del Prete****, *F. Maurano*****, *E. Tropeano*****

* Department of Civil Engineering, University of Salerno, via Ponte don Melillo,1 – 84084 Fisciano (SA), Italy, g.defeo@unisa.it

** Pro Loco di Sant'Egidio del Monte Albino, via Tenente Innocenzo Ferraioli, 148 - 84010 Sant'Egidio del Monte Albino (SA), Italy

*** Federazione Speleologica Campana, via G. Papini, 3 - 80046 San Giorgio a Cremano (NA), Italy

**** Gruppo Speleologico Natura Esplora, via Reanni, 3 - 83010 Summonte (AV), Italy

Abstract

The aim of this paper is to describe the peculiarities of a Roman aqueduct realized with the technique of the gallery in rock as well as a public fountain located in Sant'Egidio del Monte Albino, in Southern Italy. The Roman aqueduct is composed of one principal branch and three minus lateral branches. The principal branch 345.61 m in length, with a total drop of 22.9 m. While 21.25%, 0.87% and 6.73% are the maximum, minimum and average slope, respectively. The gallery does not have an uniform cross section along its length. There are also four different kinds of roof: vaulted roof, flat roof, gabled roof and uncovered roof. The Roman aqueduct is still in use and continues to supply the Helvius fountain with spring water, which is a document of great interest for the history of the river Sarno. The simultaneous presence on the fountain of two river divinities as well as Poseidon near the river mouth was designed to symbolize the river along its path. The Helvius fountain is different from the public fountains in Pompeii because it was realized from a single block of white marble.

Key words

Gallery in rock, Pompeii, Roman aqueduct, Roman fountains, river Sarno

Introduction

The availability of water in large quantities has been considered an essential part of a civilized way of life in different periods. As a matter of fact, Roman baths needed a lot of water as does the current Western way of life (Vuorinen et al., 2007).

The Romans transported water to the cities such as in a “river flow” by means of an aqueduct, whose construction started with the search for a spring. Water was collected after permeating through vaults and walls of draining channels if the spring did not emerge to the surface. Water was introduced into channels, whose section was typically rectangular, made with brick masonry or slabs of stone, and sealed with hydraulic cement (Monteleone et al., 2007).

In general, Roman aqueducts were built for the following purposes: to supply baths, military aims, domestic supplies, garden irrigation, aquatic shows, flour mills, decorative fountains and public fountains (Hodge, 2002; Tolle-Kastenbein, 2005; De Feo and Napoli, 2007).

Public fountains were usually located in the street. For example, in Pompeii the fountains were located at fairly evenly spaced intervals of about 100 metres, and it was rare for anyone to have to carry their water for more than 50 metres (Hodge, 2002).

The simplest form of street fountain was normally equipped with an oblong stone basin, typically about 1.5×1.8 m and 0.8 m high, into which the spout discharged, and which presumably was normally full. The fountains were deliberately designed to overflow in order to clean the street (Hodge, 2002).

Nowadays, the popular but inaccurate image is that Roman aqueducts were elevated throughout their entire length on lines of arches. Roman engineers were very practical and therefore whenever possible the aqueduct followed a steady downhill course at or below ground level (Hansen, 2006; De Feo and Napoli, 2007). This is particularly true for villages and small cities where an aqueduct often consisted of a simple gallery.

The excavation of a gallery in rock was considered a fundamental technique of ancient hydraulic engineering, directly derived from mining engineering. Compared to open channels, the principal advantage of a gallery in rock, consists in the fact that they are totally or partially hidden. Moreover, the slope of a gallery does not depend on the morphology of the ground (Tolle-Kastenbein, 2005).

The minimum gallery section was determined by the need of human access. Therefore, the specus was typically 1.60 metres high with a width of 70-120 centimetres (Tolle-Kastenbein, 2005).

Similar to a qanat system, a gallery in rock consisted of vertical shafts connected at their bottom with a sub-horizontal open channel bringing water from an aquiferous stratum. A vertical shaft had several functions: gallery excavation, direction orientation, aeration, cleaning and maintenance. The shafts were usually spaced 20-40 metres. In particular, Vitruvius Pollio in the Book VIII of *De Architectura* (VIII, 6, 3) suggested that the shafts had to be spaced 35 metres apart. The depth of a vertical shaft depended on both the local characteristics and whole channels design. It ranged between 13-18 metres (Tolle-Kastenbein, 2005).

The Romans were not the first to construct aqueducts. In fact, it is well known that the Greeks were the first to realize an aqueduct (Adam, 1988; De Feo and Napoli, 2007). As a matter of fact, one of the most famous aqueducts in ancient Greece was the tunnel of Eupalinos for the water supply of Samos (Angelakis et al., 2005; De Feo and Napoli, 2007).

After the two archaic system of tunnels in rock of Athens and Samos, other galleries were realized in the Classical Age (Aegina, Corinth, Agrigento, Syracuse). The tradition to excavate shafts and galleries in rock with terracotta pipes also continued in Hellenistic Alexandria. While in Isthmia, a different technique was adopted. It consisted of a tunnel sealed with hydraulic plaster with a specus of about 2.00×0.80 metres in order to directly convey water from a spring to a tank sealed in the same manner (Tolle-Kastenbein, 2005).

The same technique of using an open waterproofed channel in a rock gallery was used for the functioning of the Bologna tunnels, since the first Century A.C. The 17.8Km tunnel was constructed under the Bologna hills over a period of twelve years (Tolle-Kastenbein, 2005).

In Southern Italy, in the District of Salerno, there is a shorter (but still functioning) gallery in rock. It is situated in the village of Sant'Egidio del Monte Albino in the basin of the Sarno river, not far from the city of Pompeii (Fig. 1). The gallery in rock of Sant'Egidio del Monte Albino was probably realized during the Augustan Period in order to supply a public fountain which stands on the structure of an ancient Roman villae (the Helvius villae). The aim of this paper is to present and discuss the Roman aqueduct and the Helvius fountain in Sant'Egidio del Monte Albino, in Southern Italy with a historical and morphological approach.

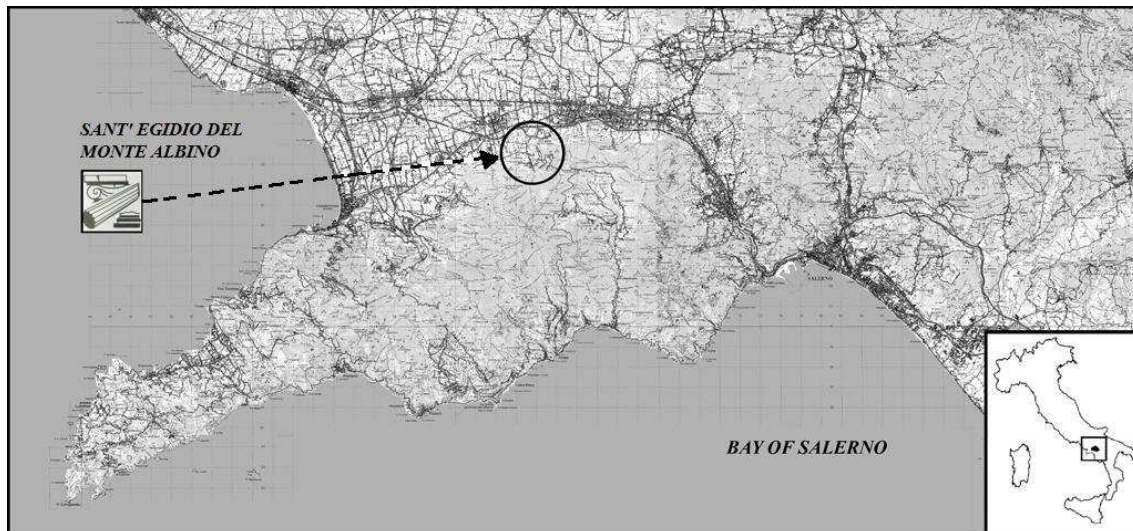

Figure 1. The village of Sant’Egidio del Monte Albino, in the District of Salerno.

The Roman aqueduct of Sant’Egidio del Monte Albino

The village of Sant’Egidio del Monte Albino belonged to the city of Nocera from Ancient Times to the Napoleonic Period. The city of Nocera was known as *Nuvkrinum Alafaternum* until VI B.C. After this period, the city was known as *Nuceria Alfaterna* until the Roman Age. In fact, during the period of the triumvirate (from 60 BC to 53 BC), the epithet “*Alfaterna*” was changed to “*Costantia*” thus giving the name *Nuceria Costantia* to the city (Prolocosantegidio, 2008a).

During this period, probably due to mass urban migration, some inhabitants of *Nuceria* began to build little settlements on the side of the surrounding mountains, outside of the city walls. They were rural settlements needing water for both agricultural and domestic uses (Prolocosantegidio, 2008a).

During the Augustan Period, an aqueduct with the technique of a gallery in rock was realized in order to collect spring water to supply the settlement of Sant’Egidio del Monte Albino. As a matter of fact, a Roman villae was discovered under the *Saint Mary Magdalene in armillis Abbey* (“*Abazia di Santa Maria Maddalena in armillis*”) as well as a white marble fountain locally known as “Saint Nicholas fountain. The villae as well as the fountain were probably due to Publius Helvius a rich praetor from Nuceria (Prolocosantegidio, 2008a).

The Roman aqueduct of Sant’Egidio del Monte Albino is still in use and continues to supply the Helvius fountain with spring water. It was entirely excavated in the rock and penetrated the mountain down to about 25metres in order to catch useful springs. A visitor passes from the amazement of the construction technique to the astonishment of the naturalistic landscape where the white of the limestone deposits shine in the hypogeum obscurity (Prolocosantegidio, 2008b).

As shown in Figure 2, the Roman aqueduct of Sant’Egidio del Monte Albino is schematically composed of one principal branch and three minus lateral branches.

The principal branch has a plan length of 340.8 m, a spatial length of 345.61 m and a total drop of 22.9 m. While 21.25%, 0.87% and 6.73% are the maximum, minimum and average slope, respectively. As it can be noted, the maximum slope is very high, probably in consequence of some landslides during the excavation which forced the labourers to a dramatic slope change. Globally, the aqueduct has a total plan length of 478.51 metres and a spatial length of 471.3 metres.

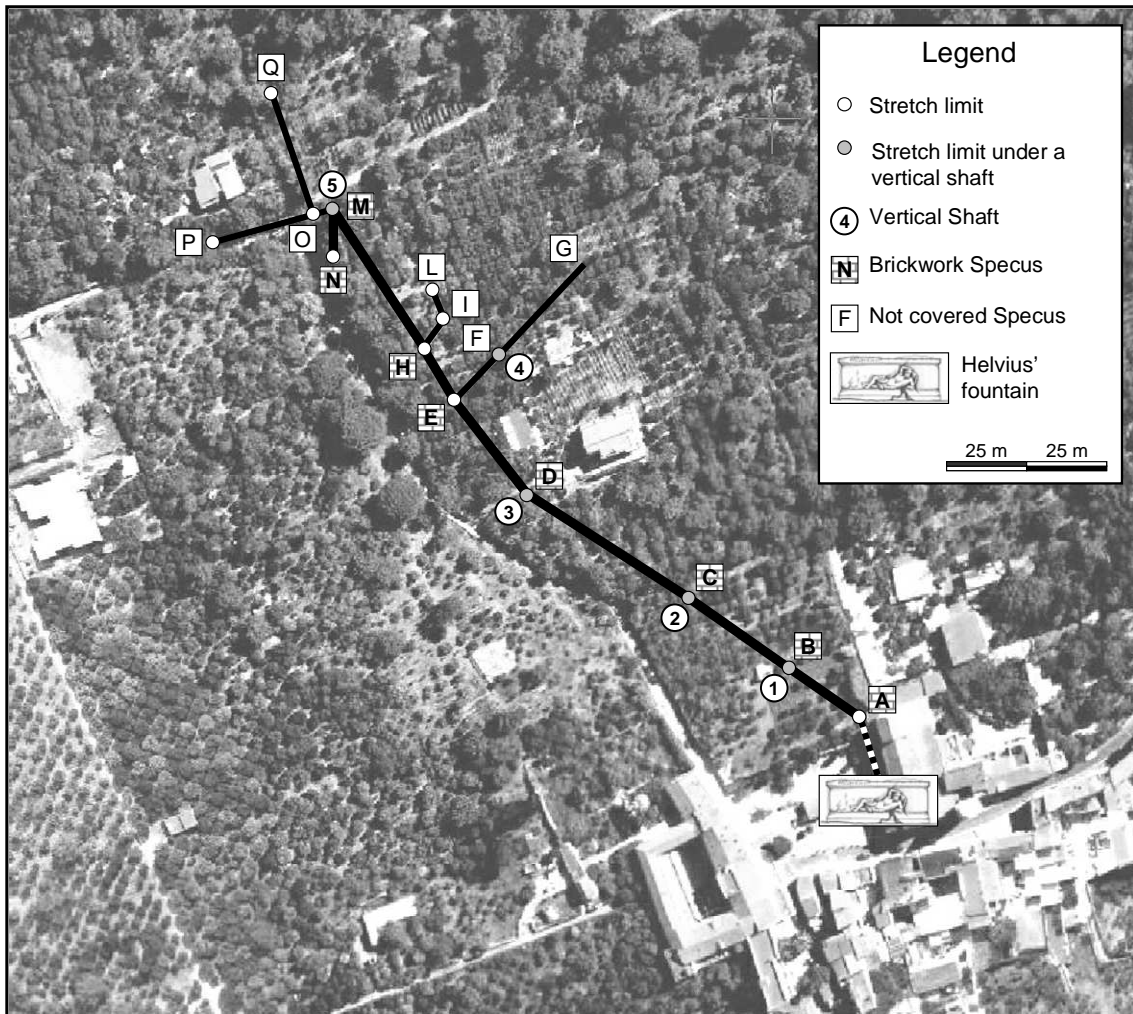

Figure 2. Schematic map of the Roman aqueduct in Sant'Egidio del Monte Albino.

The gallery in rock does not have an uniform cross section along its entire length. As a matter of fact, the principal branch is entirely covered with masonry, while the lateral branches are uncovered (Figures 3 and 4). Often the trampling plane as well as part of the lateral sides are covered by microgours (secondary mineral deposits) which sometimes also clogged the lateral raceway for the water run-off.



(a)



(b)

Figure 3. Specus of the Roman aqueduct: (a) stretches M-N and M-H; (b) stretches O-P and O-Q.



(a)

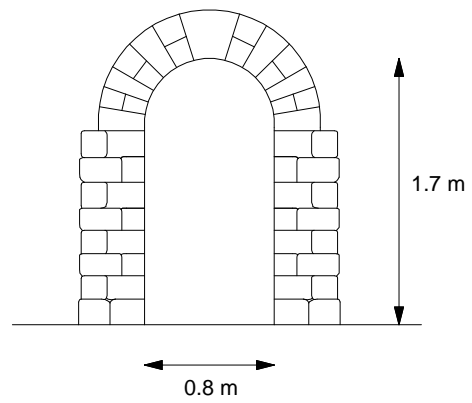

(b)



(c)

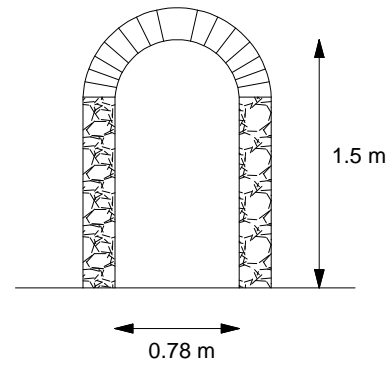

(d)



(e)

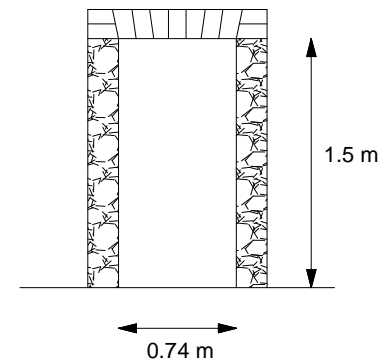

(f)



(g)

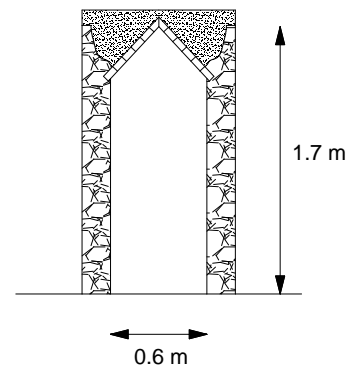

(h)

Figure 4. Specus of the Roman aqueduct: (a), (b) stretch B-C; (c), (d) stretch C-D; (e), (f) stretch D-E; (g), (h) stretch H-M.

As shown in Figure 4, the cross section of the main branch of the gallery varies in size. The width ranges between 0.6-0.8 metres, while the height ranges between 1.5-1.8 metres, with some exceptions where a visitor has to creep on the ground in order to continue along its route. Moreover, there are four different kinds of roof: vaulted roof (Figs 4a, 4b, 4c, 4d), flat roof (Figs 4e, 4f), gabled roof (Figs 4g, 4h) and uncovered roof (Figs 4a and 4b).

The Helvius Fountain

The “Helvius fountain” is locally known as “Saint Nicholas fountain” (“Fontana di San Nicola”). It is located near the *Saint Mary Magdalene in armillis Abbey* (“*Abazia di Santa Maria Maddalena in armillis*”) which stands on the structure of an ancient Roman villa. The Helvius fountain is a document of great interest for the history of the river Sarno (de’ Spagnolis, 2000; Magalhaes, 2006).

The Helvius fountain was sculpted out of a single block of white marble (Fig. 5a). It has a regular rectangular shape (Fig. 5b). The front of the fountain is 1.83 metres in length (1.52 metres internally, the marble thickness is 0.47 metres), corresponding to around 6 Roman feet (a Roman foot varied, but was around 29.6 cm). The external sides are 1.20 metres (0.78 metres internally, the marble thickness is 0.45 metres), corresponding to around 4 Roman feet. Internally, the depth is 0.50metres, while in correspondence to the corners, there are slight rises in order to allow a better cleaning of the fountain (avoid settling). The height is 0.80metres (de’ Spagnolis, 2000; Magalhaes, 2006).

The back of the fountain cannot be seen because it is partially enclosed by a modern wall (Fig. 5a). Both at the base (25 cm in height with a thickness of 6 cm) and on the top (10 cm in height with a thickness of 6 cm) of the fountain, there is a frame that runs along the three sides. Between the two frames there is a space, a central space 0.45 metres in height (de’ Spagnolis, 2000; Magalhaes, 2006).

As shown in Figure 5b, on the upper part of the fountains there is a huge flat border (22cm). All the banks of the tank are scraped. On the east side of the fountain there is the overflow. The original issue of the water is on the base of the front (de’ Spagnolis, 2000; Magalhaes, 2006).

On the frame of the front, there are the remains of an ancient inscription: “*Helvius*” (Fig. 5d). There were probably other words related to the client (or clients) and the reason of the realization of the fountain. de’ Spagnolis (2000) hypothesized that *Helvius* could be a member of the *gens Helvia* of Pompeii. He could probably have been Publius Helvius, the rich praetor from Nuceria as stated by Magalhaes (2006) and Prolocosantegidio (2008a).

The fountain can be dated back to the Augustan Age due to the use of marble as well as on the base of the stylistic aspects found. The fountain and surrounding buildings, streets and entire territory were probably buried by the eruption of Mount Vesuvius that destroyed Pompeii and Herculaneum in AD 79 (de’ Spagnolis, 2000; Magalhaes, 2006).

The Helvius fountain was a public fountain, but it was quite different from the public fountains in nearby Pompeii. As a matter of fact, the Helvius fountain was realized in marble and not in limestone nor in Vesuvian stone. It was not realized by means of matched slabs. Moreover, there is another particular aspect which differentiates our fountain from the Pompeian fountains. In fact, the Helvius fountain has a sculptural decoration on the three available sides (de’ Spagnolis, 2000; Magalhaes, 2006).



(a)

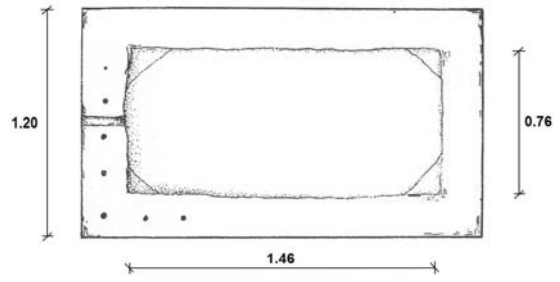

(b)



(c)

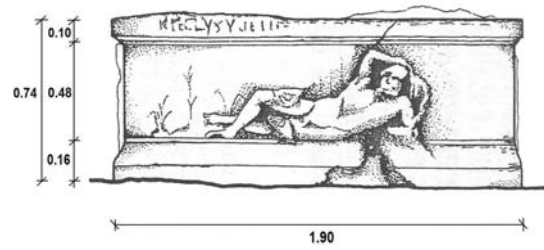

(d)



(e)

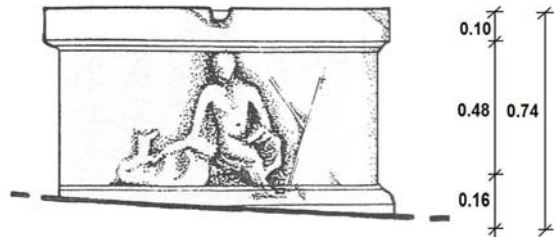

(f)



(g)

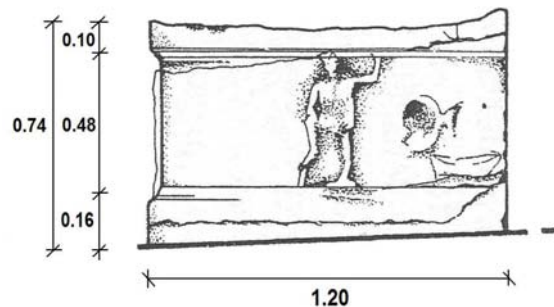

(h)

Figure 5. Helvius fountain: (a) lateral view; (b) plant (de' Spagnolis, 2000); (c) front view; (d) front (de' Spagnolis, 2000); (e) left side view; (f) left side (de' Spagnolis, 2000); (g) right side view; (h) right side (de' Spagnolis, 2000).

As shown in Figures 5c and 5d, on the frontal side, in the space between the two frames, there is a half-naked masculine figure in relief, with only *himation* wrapping-around the thighs. The figure appears half-lying on the ground with crossed legs. The facial features are not clearly visible. The nose is chipped. He has a flowing beard as well as an abundance of hair.

He is looking left, while his the left hand he is holding the horn of abundance from which water flows. The right hand, raised above his head, is holding a veil raised up in the air simulating an imaginary flowing wind from behind. The corresponding elbow is raised to touch the upper frame. The background of the front does not have landscape overtones excepted on the left where there are three *Phragmites australis* (common reed) typical of a fluvial landscape. In fact, de' Spagnolis (2000) stated that the figure described like an old bearded deity corresponds to the symbolization of the river Sarno along its path.

As shown in Figures 5e and 5f, on the left side of the fountain, there is the figure of a young man seated on a rock. He is half-naked with legs and part of the rock covered by a mantle. The young man is sitting in a meditative pose, looking down where there is a bush-hammering in the marble. His chest is rotated to the right. His right hand is on the rock, while his left hand is on the corresponding leg. His feet are on a stone. A dog is to the left of the young man. The dog is portrayed in profile with the little left forepaw on the rock, while the right one is raised. The mouth is raised towards the young master. On the right of the young man, there are two crossed spears. The figure described corresponds to the symbolization of the upstream part of the river Sarno towards the spring (de' Spagnolis, 2000).

As shown in Figures 5g and 5h, on the right side of the fountain, there is a virile figure occupying all the space between the two frames. The left leg is bent forward and the foot is placed on a not well defined oblong ledge. The right arm is on the corresponding knee. While, in his hand, he has a whip with a not well defined end. The left leg is standing, while the corresponding arm is raised with a lance in his hand. The face is almost frayed and he was probably bearded. On his head, there is something with three tips, but the principal elements of such a bonnet were lost due to the marble spalling. The virile figure probably had thick hair as well as a crown. On the right of the figure, there is a dashing dolphin. Finally, on the right of the dolphin there is a part of land with a rowing boat on the berth. The figure described corresponds to the symbolization of Poseidon whose temple was near the river mouth (de' Spagnolis, 2000).

At the end of this description, it is quite clear that the simultaneous presence of the two divinities of the river Sarno as well as Poseidon near the river mouth is not by chance but it could have been expressly designed in order to present the divinity of the river Sarno (de' Spagnolis, 2000).

Conclusions

This paper presented and discussed the Roman aqueduct as well as the Helvius fountain in Sant'Egidio del Monte Albino, in Southern Italy with a historical and morphological approach.

The following general outcomes on galleries in rock as well as public fountains can be stated:

- the excavation of a gallery in rock was considered a fundamental technique of ancient hydraulic engineering, directly derived from mining engineering;
- the slope of a gallery in rock does not depend on the morphology of the ground;

- the minimum gallery section was determined by the need of human access;
- Roman public fountains were usually located in the street;
- the simplest form of street fountain was equipped with an oblong stone basin;
- the fountains were deliberately designed to overflow in order to clean the street.

While, the following particular outcomes on the Roman aqueduct of Sant'Egidio del Monte Albino as well as the Helvius fountain can be stated:

- the Roman gallery in rock does not have a uniform cross section along its length;
- there are four different kinds of roof in the gallery (vaulted roof, flat roof, gabled roof and uncovered roof);
- the Roman aqueduct is still in use and continues to supply the Helvius fountain with spring water;
- the Helvius fountain is a document of great interest for the history of the river Sarno;
- the simultaneous presence on the fountain of two divinities of the river Sarno as well as Poseidon near the river mouth was expressly designed in order to symbolize the river along its path;
- the Helvius fountain is quite different from the public fountains in nearby Pompeii because it was made from a single block of white marble.

Acknowledgments

The authors wish to thank dr. Sacha A. Berardo for his precious contribution.

References

Adam, J.P., 1988. *L'arte di costruire presso i Romani. Materiali e tecniche*. Longanesi & C., ISBN 88-304-0855-7, Milan, Italy (in Italian).

Angelakis, A.N., Koutsoyiannis, D., Tchobanoglous, G., 2005. Urban wastewater and stormwater technologies in ancient Greece. *Water Research*, 39, 210-220.

De Feo G., Napoli R.M.A., 2007. Historical development of the Augustan aqueduct in Southern Italy: twenty centuries of works from Serino to Naples. *Water, Science and Technology: Water Supply*, Vol. 7, No. 1, 131-138.

de' Spagnolis M., 2000. *Il Sarno e i suoi Dei. La Fontana di S. Egidio Montalbino: un Documento Scultoreo per la Storia del Fiume*. In "Studi di storia e di geostoria antica. Quaderni del Dipartimento di Scienze dell'Antichità / Università degli studi di Salerno", Arte Tipografica, Naples, Italy, 185-204 (in Italian).

Hansen, R.D., 2006. *Water and wastewater systems in imperial Rome* [available on line at: www.waterhistory.org].

Hodge A.T., 2002. *Roman aqueducts & water supply*. Second Edition. Gerald Duckworth & Co. Ltd, ISBN 0715631713, London.

Magalhaes M.M., 2006. *Sant'Egidio del Monte Albino: la Fontana di San Nicola ed un magistrato di Nuceria Constantia*. In "Nuceria – Scritti storici in memoria di Raffaele Pucci", Altrastampa Edizioni, Napoli, Italy (in Italian).

Monteleone M.C., Yeung H., Smith R., 2007. A review of Ancient Roman water supply exploring techniques of pressure reduction. *Water Science & Technology: Water Supply*, Vol. 7, No 1, 113-120.

Prolocosantegidio, 2008a. *Archeologia* [available on line at: <http://prolocosantegidio.it/archeologia.html>] (in Italian).

Prolocosantegidio, 2008b. Archeologia [available on line at: http://prolocosantegidio.it/Archeologia/acquedotto_romano.html] (in Italian).

Tolle-Kastenbein Renate, 2005. Archeologia dell'acqua. Longanesi - Collana: Biblioteca di archeologia. ISBN 8830411655, Italy (in Italian).

Vuorinen H.S., Juuti P.S., Katko T.S., 2007. History of water and health from ancient civilizations to modern times. Water Science & Technology: Water Supply, Vol. 7, No. 1, 49-57.